

Product range

Series 5

Pitch 25 mm (1 in)

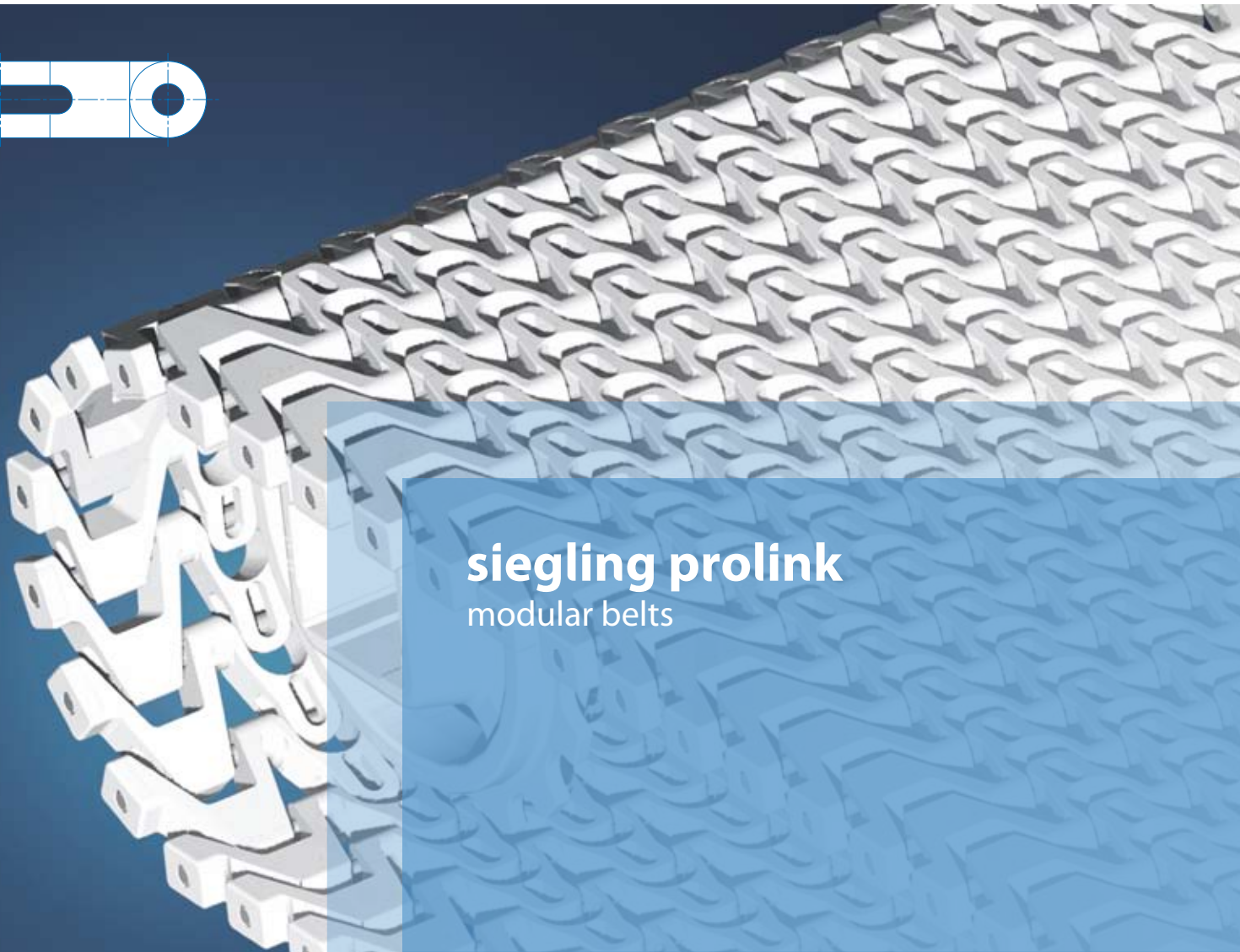

siegling prolink
modular belts

Siegling Prolink

Series 5

Curved modules,
pitch 25 mm (1 in)

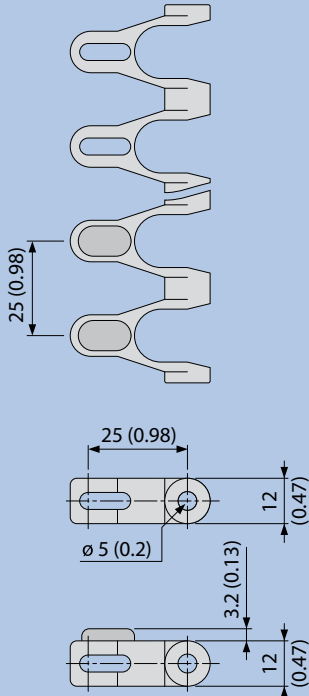
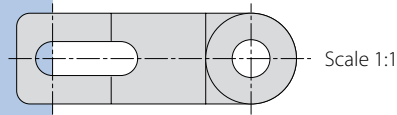

Side modules

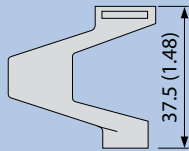

Side modules
reinforced (ST)

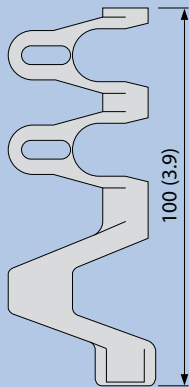

Design characteristics

- Curved and spiral belt with stainless steel hinge pins for conveying medium-weight goods. Exceptionally strong and permeable.
- Minimum turning radius of 2 x belt width.
- Large open area provides excellent product drying and cooling capability.
- Used for spiral cooling towers, spiral freezers and radius conveyors in food industries such as baking, meat and poultry processing and processed foods.

Pitch

25 mm (1 in)

Belt width min.

100 mm (3.9 in), 175 mm (6.9 in) for S5 ST (side modules only available without FRT- and without NTP-pattern).

Width increments

In increments of 25 mm (1 in).

Hinge pins

Stainless steel (plastic pins can also be used for straight conveyors).

Certification

For certification see fold-out page.

Technical notes

Minimum curve radius = 2 x belt width.
Minimum length of the straight in-feed/
out-feed section before and after the
curve = 2 x belt width.

Comments

ST types combinable with standard centre
curve modules, NTP, FRT.
ST types not combinable with Guided (G),
Side Guards (SG) or Bearing Tab (BT).

Please contact us should you require small
curve radii.

Belt types

S5-45 GRT

Lattice-shaped surface with large open area

S5-45 GRT G

Lattice-shaped surface with large open area
and hold-down tabs

S5-45 NTP

Particularly permeable, lattice-shaped surface
with 1.7 mm/0.07 in high round studs

S5-45 FRT

Very permeable, lattice-shaped surface
with friction top

S5-45 GRT ST

Reinforced version of series 5. Wide outer
modules (75 mm/2.9 in and 100 mm/3.9 in)
ensure extra belt stability and better trans-
mission of force in curves

Profile and side guard designs/ special modules

Profiles

25, 50 mm (1, 2 in) height

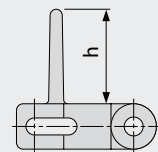

Key dimensions in mm and inches (in), scale 1:2.
All imperial dimensions (inches) are rounded off.

Materials	Colours	Open area [%]	Allowable belt pull [N/mm (lb/ft)] (Straight)	Allowable belt pull [N (lb)] (Curves)	Weight [kg/m ² (lb/ft ²)] (Stainless steel pins)
PE		45	10 (685)	–	11 (2.3)
PP	WT/DB	45	18 (1233)	1000 (225)	10 (2.1)
POM	WT/DB	45	25 (1713)	1800 (405)	13 (2.7)
PE		45	10 (685)	–	11 (2.3)
PP	WT/DB	45	18 (1233)	1000 (225)	10 (2.1)
POM	WT/DB	45	25 (1713)	1800 (405)	13 (2.7)
PE		45	10 (685)	–	11.2 (2.3)
PP		45	18 (1233)	1000 (225)	10.1 (2.1)
POM		45	25 (1713)	1800 (405)	13.2 (2.7)
PP		45	18 (1233)	1000 (225)	10.2 (2.1)
PE		47	10 (685)	–	11.1 (2.3)
PP	WT/DB	47	18 (1233)	1200 (270)	10.2 (2.1)
POM	WT/DB	47	25 (1713)	2100 (473)	13.2 (2.7)



Sprockets

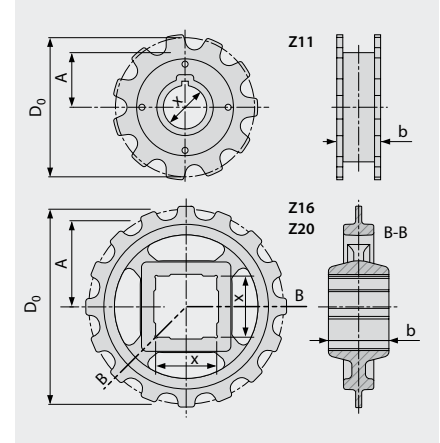

Sprocket size	Z11 DR	Z16	Z20
b [mm]	29	40	40
[in]	(1.1)	(1.6)	(1.6)
D ₀ [mm]	89	129	161
[in]	(3.5)	(5.1)	(6.3)
A [mm]	38	58	78
[in]	(1.5)	(2.3)	(3.1)
x [mm] (sprocket bore metric)			
25	●		
30	●	●	●
40	■	■	■
x [in] (sprocket bore imperial)			
1		●	●
1.5	■	■	■

- Sprocket bore round
- Sprocket bore square

D₀ Pitch circle diameter

A Distance centre of sprocket bore/
top edge support

DR Double row sprocket

The fold-out page at the back will explain all abbreviations used and the type designation.

Side guards

25, 50 mm (1, 2 in) height

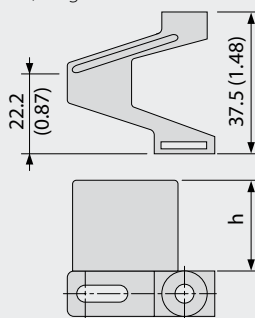

Guided version (G)

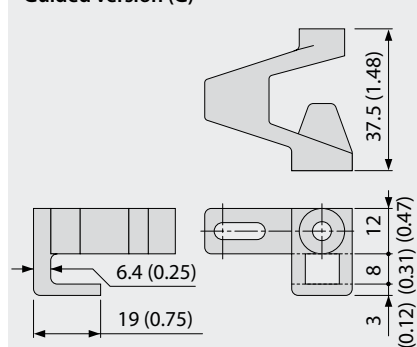

Ball-bearing (BT) module

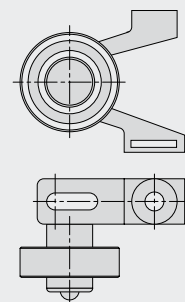

Type designation, key

Type designation*

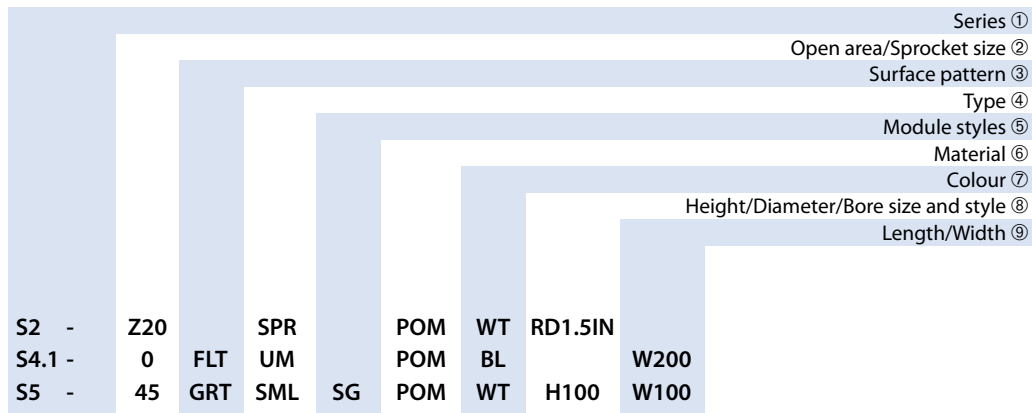

Key

① Series S1 S2 S3 S4.1 S5 S6.1 S7 S8 S9	④ Type CM = Centre module SML = Side module, left SMR = Side module, right SMU = Side module, universal/both sides UM = Universal module PMC = Profile module centre PMU = Profile module universal PMU lxx = Profile module universal with indent xx = indent in mm CLP = Clip RI = Rubber insert SG = Module with sideguard PIN = Coupling rod FPL = Finger plate SPR = Sprocket RTR = Retaining ring TPL = Turning panel, left TPR = Turning panel, right	⑥ Material PA 6.6 = Polyamide PA 6.6-HT = Polyamide high temperature PBT = Polybutylenterephthalate PE = Polyethylene PE-HA = PE with HACCP batch PE-MD = PE metal detectable POM = Polyoxymethylene (Polyacetal) POM-CR = POM cut resistant POM-CRHA = POM cut resistant with HACCP batch POM-HA = POM with HACCP batch POM-HC = POM highly conductive POM-MD = POM metal detectable POM-UV = POM UV-resistant PP = Polypropylene PP-HA = PP with HACCP batch PP-HC = PP highly conductive PXX = Self-extinguishing material PXX-HC = Self-extinguishing highly conductive material PPA = Polyphthalamide PPA POM-PE = POM side modules + PE centre modules POM-PP = POM side modules + PP centre modules SER = Self-extinguishing rubber SS = Stainless steel	⑦ Colour** AT = Anthracite BL = Blue BG = Beige BK = Black DB = Dark blue GN = Green LB = Light blue LG = Light grey OR = Orange RE = Red TR = Transparent WT = White YL = Yellow
② Open area/Sprocket size Percentage open area Format: xx E.g. 20 = 20 % For sprockets: number of teeth Format: "Z"xx E.g. Z12 = 12 teeth	⑤ Module styles BT = Bearing tap G = Guided SG = Side guard ST = Strong (S5) DR = Double row sprocket SP = Split sprocket F1, F2, = Collapse factor F3 ... modules	⑧ Height/Diameter/Bore size and style Height in mm Format: Hxxx Pin diameter in mm Format: Dxxx Bore size: SQ (= square) or RD (= round) either in mm or inches Format: SQxxMM or RDxxIN	⑨ Length/Width Pins Length in mm Format: Lxxx Module width in mm Format: Wxxx

* Not every product requires all characteristics (within the designation).
If there is an irrelevant characteristic, this category will be ignored and replaced by the following one.

** Please refer to the table of types for each series' standard colours.
A number of other colours are available on request.
Colours can vary from the original due to the print, production processes or material used.

Temperature ranges/HACCP types/materials

Temperature ranges in °C

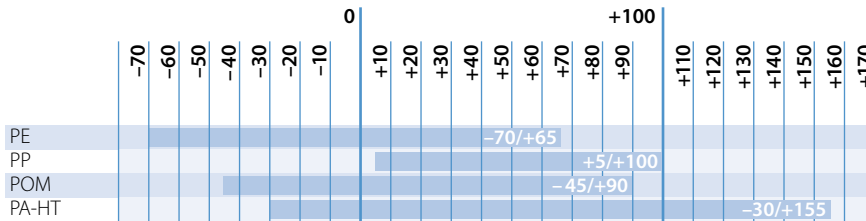

Temperature ranges in °F

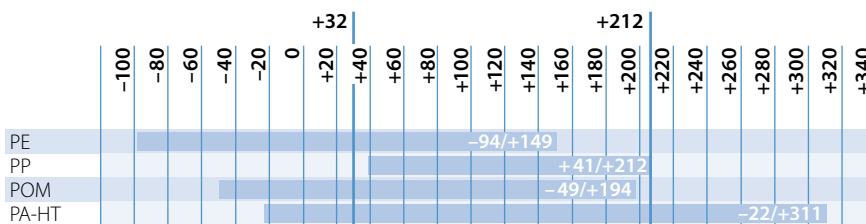

HACCP types/certification

Siegling Prolink modular belts made of PE, PP and POM comply with FDA directives and the regulations (EU) 10/2011, (EC) 1935/2004 as well as the associated directives on the materials used and migration levels.

Due to a variety of hygiene-friendly properties, some series support your HACCP concept. These properties include:

Excellent resistance to hydrolysis

- resistant to hot water, cleaning agents and disinfectants

Good release properties

- beneficial when manufacturing adhesive foodstuffs (minimal product wastage)
- product residue is easy to remove
- easy-to-clean hinge design

Blue a strong colour contrast

- soiling is easier to identify
- suitable for usage in optical sorters
- reduces light reflection, making working conditions better

Materials

PE (Polyethylene)

- very good chemical resistance to acids and alkalis
- very good release properties due to low surface tension
- good friction and abrasion behaviour
- extremely tough
- low specific weight

PP (Polypropylene)

- standard material for normal conveying applications
- quite strong and stiff
- good dynamic capacity
- highly resistant to acids, alkalis, salts, alcohols
- low specific weight
- no risk of stress cracks forming

POM (Polyoxymethylene/Polyacetal)

- very dimensionally stable
- very strong and stiff
- high chemical resistance to organic solvents
- lower drag
- very durable material
- hard, incision-resistant surface

POM-CR (POM cut resistant)

- highly resistant to impact and incision
- easy to clean
- minimal ridge formation
- low risk of material delamination

POM-HC (POM highly conductive)

- highly conductive material
- surface resistivity < 10⁶ Ω (according to specification)
- very strong and stiff
- very good friction and abrasion properties

POM-MD (POM metal detectable)

- material easily detected in metal detectors
- very strong and stiff
- very good tribological properties (friction and abrasion levels)

PA 6.6-HT (Polyamide high temperature)

- material reinforced with fibre glass
- very high short-term temperature resistance up to 180 °C (356 °F)
- absorbs little water in humid environments
- very stiff
- durable

PXX-HC (self-extinguishing highly conductive material)

- flame retardant in line with DIN EN 13501 (B_{fl}-s1) and DIN 4102 (B1)
- surface resistivity < 10⁶ Ω
- specially for use in the automotive industry

PBT (Polybutylenterephthalate)

- good wear resistance
- very good abrasive resistance
- good strength and stiffness

PXX (self-extinguishing material)

- quite strong and stiff
- good dynamic capacity
- highly resistant to acids, alkalis, salts, alcohols

Siegling – total belting solutions

Committed staff, quality-orientated organisation and production processes ensure the constantly high standards of our products and services. The Forbo Siegling Quality Management System is certified in accordance with DIN EN ISO 9001.

In addition to product quality, environmental protection is an important corporate goal. Early on we also introduced an environmental management system, certified in accordance with ISO 14001.

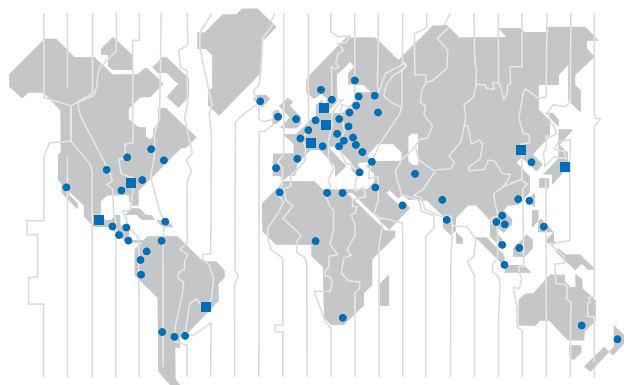

Forbo Siegling Service – anytime, anywhere

In the company group, Forbo Siegling employs more than 1800 people worldwide. Our production facilities are located in eight countries; you can find companies and agencies with stock and workshops in more than 50 countries. Forbo Siegling service centres provide qualified assistance at more than 300 locations throughout the world.