

siegling transilon

conveyor and processing belts

Technical Information 1

Storage, Finishing, Fitting

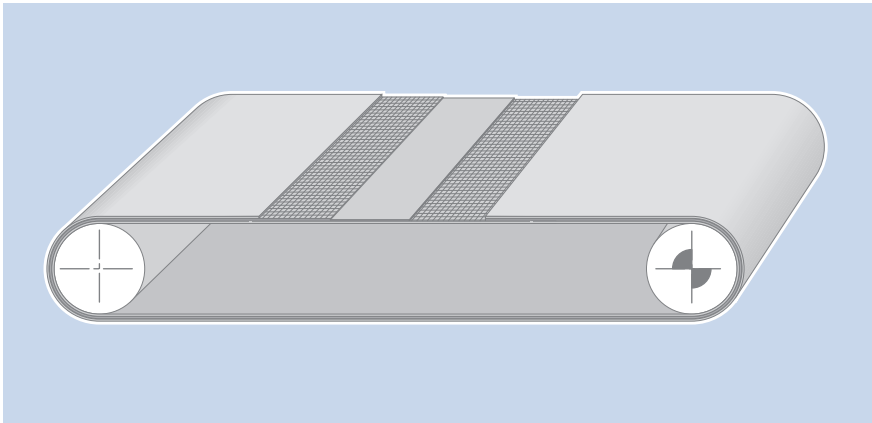

Siegling Transilon conveyor and processing belts are high quality products that are durable, easy to handle, require no maintenance and are economical to operate.

From strong "allrounders" to high-tech "specialists", our product range includes over 120 types and designs for the most varied of conveying and processing tasks in all industries.

In this publication you will find important basic information about your conveyor and processing belt.

Further information about belts with special mechanical, physical or chemical properties, textures, profiles and sidewalls as well as about curved belts can be found in our brochure ref. no. 318 "Technical Information 2".

Contents

Construction and material	2
Type designation	2
Transport and storage	3
Resistance	3
Care	3
Availability, standard sizes and tolerances	4
Splice types	6
Splicing equipment	7
Fitting	8

Construction and Material

Tension member design	
AE	Aramid/polyester blended fabric
E	Polyester
EC	Polyester/cotton blended fabric
EP	Polyester/polyamide blended fabric
P	Polyamide

Design	
1, 2, 3	Number of fabric plies
M	Solid-woven fabric
NOVO	Polyester non-woven
H	HighTech-fabric

Surface materials	
A	Polyolefin
C	Cotton
E	Polyester
G	Rubber/elastomer
P	Polyamide
S	Silicone
U	Urethane
UH	Hard urethane
V	PVC
VH	Hard PVC
VS	Soft PVC
0	Uncoated
F, Z	Felt/velour
U0, E0,	Impregnated
A0, S0, Y0	

Surface patterns	
AR	Anti-skid pattern
CH	Check-in pattern
FG	Herringbone pattern
FSTR	Fine textured pattern
GL	Smooth surface
GSTR	Coarse textured pattern
KN	Cross-stud pattern
LG	Longitudinal groove
MT	Matt surface
NP	Inverted pyramid pattern
R	Large diamond pattern
RF	Fine rhomboid pattern
RFF	Flat fine rhomboid pattern
RPH	High round profile pattern
R80	Rhomboid pattern
SG	Lattice pattern
SP	Star pyramid pattern
STR	Normal textured pattern
VN	Staggered stud pattern
WAR	Wavy anti-skid pattern
Rough	Rough pattern
Fine	Fine pattern

Belt properties	
ATEX	Explosion protection with specific compliance to guidelines
C	Laterally flexible, suitable for curved belts
FDA	FDA-compliant
HACCP	Supports the HACCP concept
HC	Highly-conductive
HW	Hot water
LF	Low friction
M	Particularly stiff laterally
NA	Non-antistatic
S	Very low noise
SE	Flame retardant
TT	Pyrolysis compliant
Q	Laterally soft tension member, not for curved belts

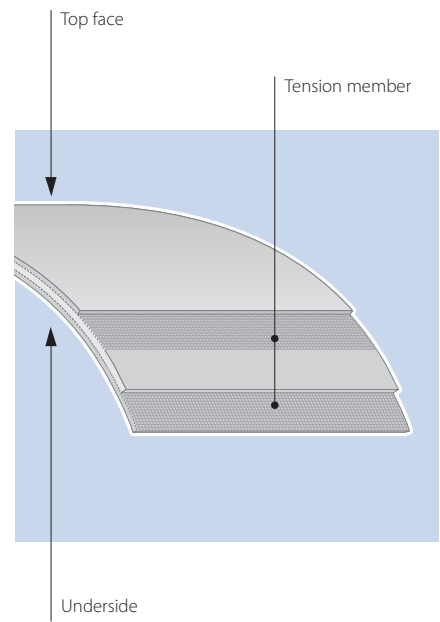

Type designation



Transport and Storage

Transport Siegling Transilon in such a way that it cannot be creased or damaged by sharp edges. Do not tip the belt on its edges.

Transport belt material on a firm base, on a carrying rod inserted through the packaging core, by fork lift, with lifting sling, by handcart or similar device.

Whenever possible, only remove packaging at fitting site. Avoid unrolling or pulling belt on dirty or rough floor.

Store Transilon in a cool and dry location, ideally at standard ambient conditions of 20°C/50% humidity.

Major fluctuations from standard ambient conditions may change resistance of surface materials.

Therefore, protect material from:

- direct sunlight
- high temperatures in conjunction with high humidity
- low temperatures
- or other extreme conditions.

Do not place material on belt edge, but

- hang it on a pipe inserted in the packaging core,
- or set it flat on a shelf or pallet.

Before fitting in the workshop allow Siegling Transilon to acclimate to ambient temperature.

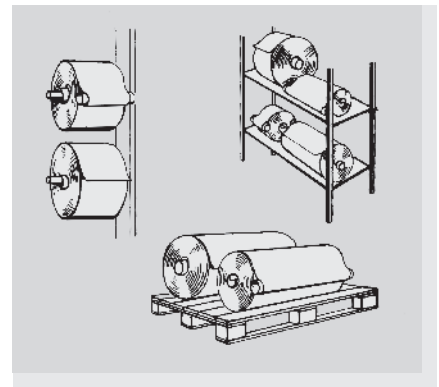
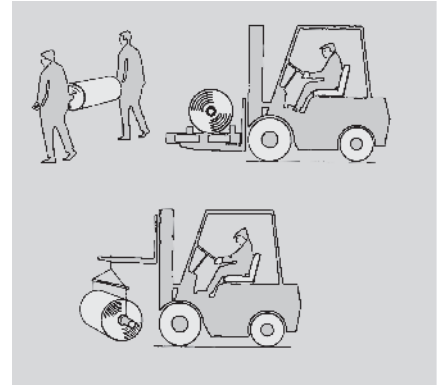

Resistance and Care

Depending on the coating, Siegling Transilon is safe, corrosion and rot resistant, largely impervious to oils, greases, and many chemicals. Further details are available in the product information on our web site or on request.

We recommend you test resistances yourself according to prevailing operating conditions and other influences affecting the belt.

Siegling Transilon belts can easily be cleaned with lukewarm water. Very greasy patches can be removed with alcohol from V (PVC) coatings or with white spirit from U (urethane) coatings. Then clean with water. (Please inquire about P coatings.)

We recommend that belt, drums, support rollers and skidplates be kept clean at all times.



MOVEMENT SYSTEMS

Availability, standard sizes and tolerances

Siegling Transilon conveyor and processing belts are available as

- endless belts
- belts prepared for hot or cold-pressing on-site
- roll material for individual fabrication
- belts with metal or plastic mechanical fasteners
- belts with sealed edges (ProSeal)
- belts with profiles welded on (longitudinal, lateral, diagonal, half-round)
- belts with sidewalls
- belts with perforations
- special constructions with metal eyelets, trip foil strips, special labelling, etc.

Information about the finishing of special types such as profile, perforated or curved belts can be found in our brochure ref. no. 318 "Technical Information 2".

Roll material

Production lengths, roll diameter, weight and width are limited for roll material. The following are available as one piece:

Types	Length
1-ply, 2-ply without pattern	to 550 m
3-ply without pattern	to 275 m
E 10/M without pattern	to 250 m
E 10/M with pattern, E 15/M	to 180 m
E 20/M	to 135 m
Patterned belts	on request

Larger sizes and constructions with profiles or sidewalls often require special transport devices. Please inquire.

Minimum lengths for endless belts [mm]

Belt width	Shortest belt lengths (mm)	
	splice <) 90°	splice <) 80° (on request)
up to 200	700	950
up to 300	700	1000
up to 400	700	1050
up to 500	700	1150
up to 600	900	1250
up to 800	900	1400
up to 1000	1250	1550
up to 1250	1300	1750
up to 1500	1400	2000
up to 1750	1400	2300
up to 2000	1400	2600
up to 2250	1600	2900
up to 2500	1600	3200
up to 2750	1600	3500
up to 3000	1600	3800
up to 500	2300	4500
up to 4000	2300	5000
up to 4400	2300	5500
up to 5000	2500	
up to 6000	2500	

Please inquire about shorter belt lengths and larger belt widths.

Sets of belts

We fabricate sets of belts of the same length.

max. Length = 10500 mm

max. width of set = 600 mm

Special types on request.

When ordering please specify which belts belong to one set so that they can be supplied bundled as a set. Slight differences in length which cannot be avoided with synthetics can best be counterbalanced by placing the longest belts in the centre of the set when fitting.

Maximum widths, approx. [mm]

Types	Endless belts without long. seam	Endless belts with 1 long. seam	Endless belts with 2 long. seams
one-ply	to 4.700*	on request	on request
2-ply/3-ply*	1400	2700	4000
	1500	2900	4300
	3000	6000	6000**
	4600*	6000	6000**
E 10/M (U)	1450	2800	4200
E 10/M (V)	3000	6000	6000**
E 15/M	2500	5000	6000**
E 20/M	1600	3100	4600

* types available on request
 ** larger widths available on request

Transilon is produced in widths of 1400 to 4700 mm, depending on the type and surface material. Belts longer than 30000 mm with widths over 3000 mm available on request.

Note:

If they can be supplied with a longitudinal seam, belts with patterned top faces may have small changes in the pattern in the area of the seam.

If two longitudinal seams are required, they will be fabricated symmetrically to the centre of the belt.

Fabrication tolerances

Width tolerances***		Length tolerances	
from 10 to 200 mm	± 2 mm	from 700 to 1500 mm	± 0,8 %
over 200 to 600 mm	± 4 mm	over 1500 to 2500 mm	± 0,5 %
over 600 to 1400 mm	± 6 mm	over 2500 to 5000 mm	± 0,4 %
over 1400 to 2700 mm	± 10 mm	over 5000 to 10000 mm	± 0,3 %
over 2700 to 4300 mm	± 14 mm	over 10000	± 0,2 %
over 4300 to 6000 mm	± 18 mm		

*** for belts with longitudinal seam tolerance values are double in the width

These fabrication tolerances are determined by the fabrication process.

These tolerances do not include changes in width or length which can arise after fabrication due to fluctuations in ambient conditions or other external factors.

The tolerance range may not be extended up or down arbitrarily.

Special tolerances are also possible. Please ask.

In order to guarantee repeat accuracy around the splice there are different length tolerances for Transilon with special surface imprints such as for example in the CH, R80, R, KN, VN pattern.

Please note the repeat info and different length tolerances in the technical product data sheets.

Types of splices

The appropriate splicing method for individual belts depends on the belt type, the application and the individual operating conditions.

Decisive criteria for selecting the splicing method are, in addition to the splice reliability, also the flexibility of the splice and the properties required by the application technology.

Detailed splicing instructions available on request.

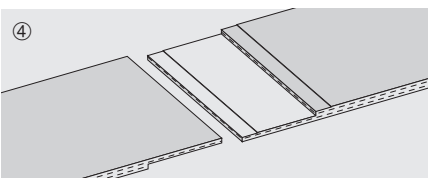
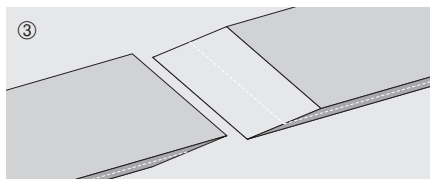
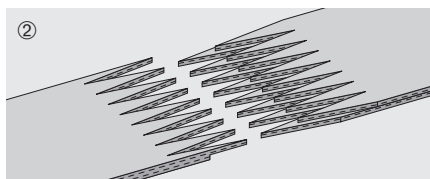
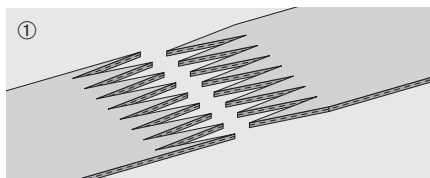

Hot-press method

A hot-pressed splice provides the greatest durability and flexibility. Following versions are possible:

■ Z-splice ①

Meets the most stringent requirements for uniformity of thickness. Very flexible splice, especially well suited for knife edge belts. Standard splice angle is 90° (60° is possible).

■ Stepped Z-splice ②

Similar properties as the Z-splice. Also suitable for harsh operating conditions. Possible on various 2 and 3-ply belt types. Splice angle is 90°.

■ Wedge splice ③

Splice type used for solid-woven and NOVO types. Splice angle is 90°.

■ Overlap splice ④

Especially well suited for 2 and 3-ply belt types with duroplastic surface materials. Splice angle is 90° or 80°.

Cold-press method

It is possible for customers to cold-press wedge or overlap splices independently when fitting or repairing on-site. Please note that splice strength and flexibility are limited.

Mechanical fasteners

Mechanical fasteners make it possible

- to replace belts speedily without dismantling machine components,
- to repair belt quickly by inserting a piece of belt,
- to make belts endless quickly and easily (for details about lacers please inquire).

Available fasteners:

■ **Hook fasteners (HS) ⑤**, stainless, antimagnetic, sheathed connecting rod, can also be imbedded or heated into belt surface material

■ **Clamp fasteners (CS) ⑥**, stainless or standard, sheathed connecting rod

■ **Plastic fasteners (KS) ⑦**, white polyester, FDA, heated into belt surface material

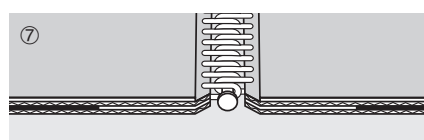
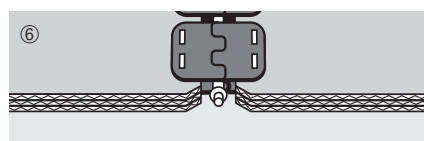
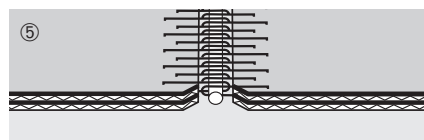

Fasteners	D _{min}
HS-00/HS-01	25
HS-02/HS-03	50
HS-05/HS-06	75
HS-09	100
HS-11/HS-12/HS-13	50
HS-14/HS-15	75
HS-16	50
CS-05	50
CS-06	75
CS-07	100
KS-fasteners	25 (Z, S) 60 (U)

Splicing equipment

For the reliable splicing of Siegling Transilon conveyor and processing belts, a diverse range of tried-and-tested equipment is available.

Which is the best device depends on the type of splice and the belt width. Another factor is the conditions under which the splice is to be fabricated (in the workshop or on-site fitting).

The devices depicted below are just a selection from our equipment range. Further information about the uses of the individual splicing devices is available on our web site or on request.

Splice type	Equipment for preparation	Equipment for hot-pressing
Z-splice	PP-ZP-XX/XX	SM-HP-XX/XX, SM-HD-110/2000, SM-RD-120/XXX
Stepped Z-splice	PS-PM-110/V + PP-ZP-XX/XX	SM-HP-XX/XX
Wedge splice	PS-WD-70/V, PG-GM-V/130	SM-HP-XX/XX
Overlap splice	PS-PM-110/V/manually	SM-HP-XX/XX

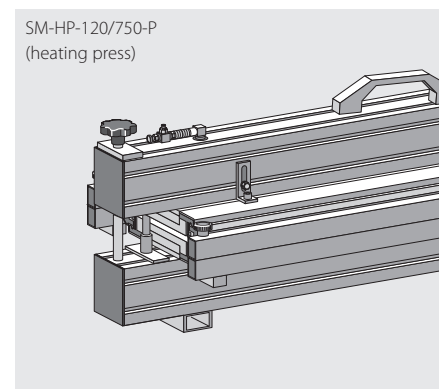
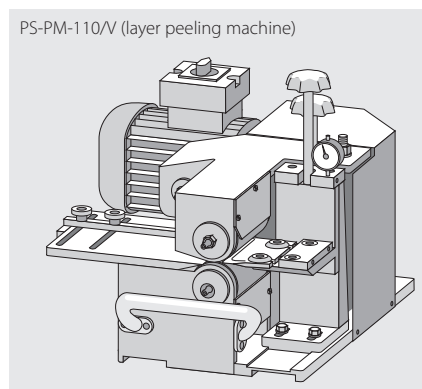
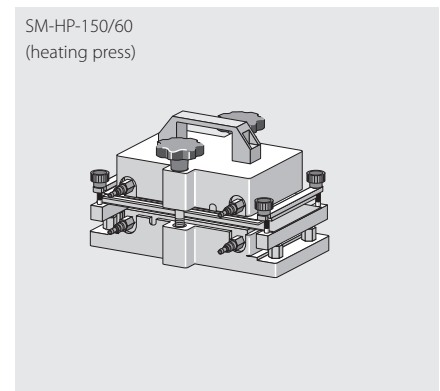
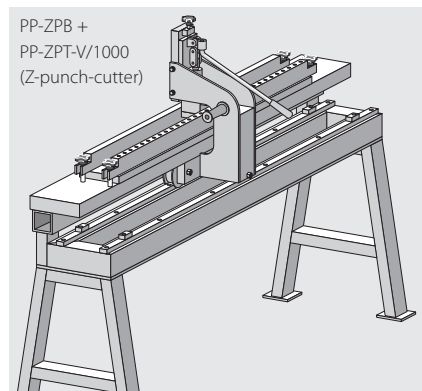

Fitting

All work carried out on the conveyor must be in accordance with the manufacturer's operating instructions and any applicable legal stipulations or safety regulations in each country. When splicing and repairing Siegling Transilon follow the instructions for specific processes and types, available on request. Recommended elongation at fitting 0.2 to 1.0 %. For higher loads we recommend calculating elongation at fitting using our calculation programme B_Rex.

Operational direction

Conveyor belts subjected to unusual loads should as a rule only be made end-less using a Z-splice or stepped Z-splice. If an over-lap or wedge splice is used instead the following must be noted concerning the operational direction.

For unusual loads on the top face from scrapers, brushes, accumulation etc the splice lap must always decline from the top face (fig. 1).

For unusual loads on the underside from scrapers, brushes, fixed knife edge etc and for belt operation without unusual loads the splice lap must always decline from the underside (fig. 2).

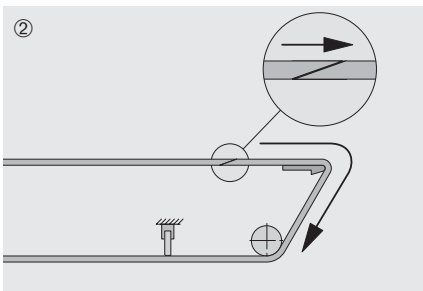
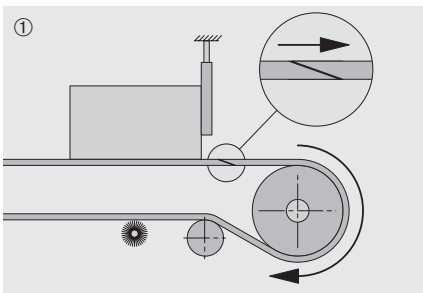

Fitting

Before fitting the belt on the conveyor, ensure that the conveyor is in perfect operating condition, taking any necessary steps. Clean drums, support rollers and skid plate, removing any residues. Prepare the conveyor for the insertion of the conveyor belt.

Feed conveyor belt carefully into place and avoid creasing it. With large belt rolls use retarder to prevent whole belt material from unrolling.

– for endless conveyor belts:

Move take-up unit(s). If necessary, disassemble reversing/drive drum, insert into belt loop and reassemble.

– for open conveyor belts:

Move take-up unit(s). Feed belt laps around drums and place in a position for splicing.

Remove protective coverings from belt laps. Keep belt laps clean! Clean dirty belt laps with white spirit or benzine before splicing. Follow splicing instructions to splice belt.

Trial run

After fitting belt, evenly apply slight and even tension. Observe belt travel and if required correct by adjusting the drums.

After trial run, tension conveyor belt only as much as is necessary to convey goods properly under full load (see our brochure "Recommendations for Conveyor Design").

For normal operating conditions (temperatures to approx. +25 °C) move gravity take-up in order to be able to exploit take-up range fully.

In cases of extreme temperature variation, set take-up approx. in middle so that length fluctuations of at least 0.3 % can be absorbed.

Because our products are used in so many applications and because of the individual factors involved, our operating instructions, details and information on the suitability and use of the products are only general guidelines and do not absolve the ordering party from carrying out checks and tests themselves. When we provide technical support on the application, the ordering party bears the risk of the machinery functioning properly.